

## FITTING INSTRUCTION

Clamp mark in acc. with		Cables joining
ISO	PN	
1	L	Left directional lights
2	+	Rear fog lights
3	31	Ground
4	R	Right directional lights
5	58R	Right side parking lights
6	54	Stoptlights
7	58L	Left side parking lights

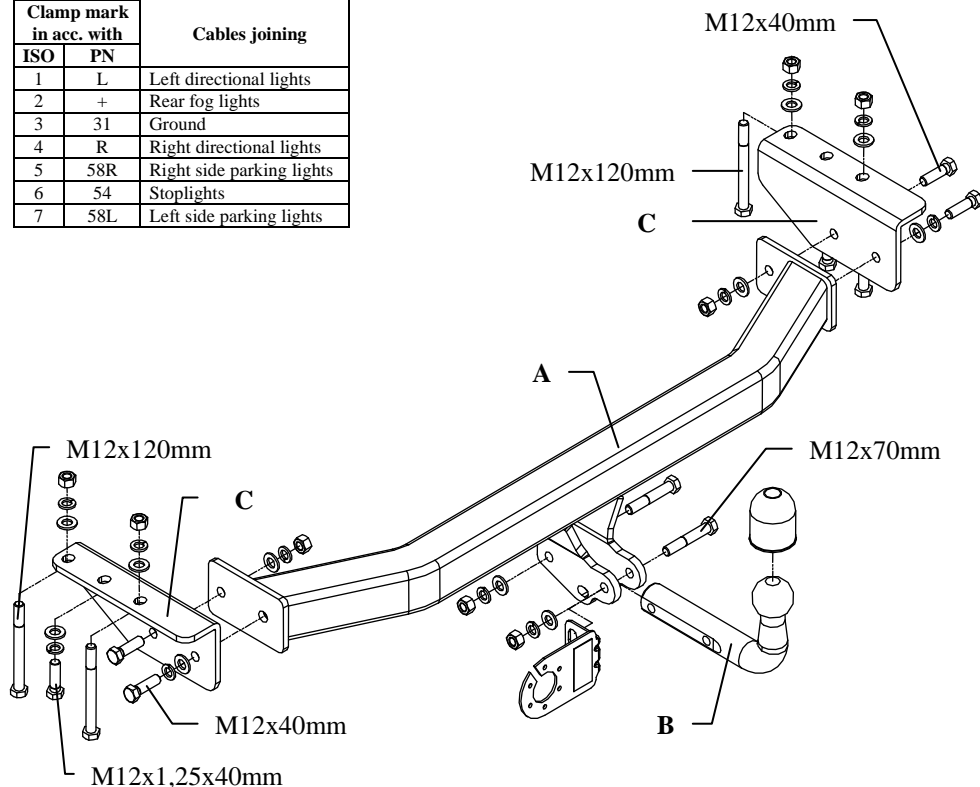

This towbar is designed to assembly in following car: **MITSUBISHI PAJERO SPORT, 5 doors, (K90)** produced since 07.1996 till 2008, catalogue no. **Z29** and is prepared to tow trailers max total weight **2800 kg** and max vertical load **115 kg**.

### Foreword

Thank you for buying our product. This towbar is design according to rules of safety traffic regulations and their reliability has been confirmed in many tests. Reliability of towbar also depends on correct assembly and correct exploitation. For this reasons we kindly ask to read carefully this instruction and apply to hints.

*The towbar should be install in places described by a car producer.*

## The instruction of the assembly

1. Unscrew fabric tow handles (not used any more).
2. Put brackets (pos. C) to the frame of chassis (in places unscrewed handles) and screw it loosely using bolts M12x120mm (see drawing).
3. Between handles (pos. C) slip main part of the towbar (pos. A) and screw using bolts M12 x 40 mm from equipment.
4. Screw tow-ball (pos. B) and socket plate using bolts M12x70mm from equipment.
5. Screw all bolts according to the torque shown in the table.
6. Connect electric wires according to the instruction of the car. (Recommend to make at authorized service station)
7. Supplement the paint coating damaged during assembly.

Torque settings for nuts and bolts (8,8):

<b>M6</b> - 11 Nm	<b>M 8</b> - 25 Nm	<b>M 10</b> - 50 Nm
<b>M 12</b> - 87 Nm	<b>M 14</b> - 138 Nm	<b>M16</b> - 210 Nm

### NOTE

After install the towing hitch you should get adequate note in registration book (at authorised service station). The car should be equipped with:

- Indicators
- Tow mirrors

After 1000km of exploitation check all bolts and nuts. The ball of towing hitch must be always kept clear and conserve with a grease.



**PPUH AUTO-HAK Sp.J.**

Produkcja Zaczepów Kulowych  
Henryk & Zbigniew Nejman  
76-200 SŁUPSK ul. Słoneczna 16K  
tel/fax (059) 8-414-414; 8-414-413  
E-mail: [office@autohak.com.pl](mailto:office@autohak.com.pl)  
[www.autohak.com.pl](http://www.autohak.com.pl)

---

## **Towing hitch (without electrical set)**

Class: **A50-X** Cat. no. **Z29**

Designed for:

Manufacturer: **mitsubishi**

Model: **PAJERO SPORT**

Type: **5 doors (K90)**

produced since 07.1996 till 2008

Technical data:

**D-value: 13,3 kN**

maximum trailer weight: **2800 kg**

maximum vertical cup mass: **115 kg**

**Approval number acc. to regulations EKG/ONZ 55.01: E20-55R-01 4758**

### ***Foreword***

This towing hitch is designed according to rules of safety traffic regulations. The towing hitch is a safety component and can be install only by qualified personnel. Any alteration or conversion of the towing hitch is prohibited and would lead to cancellation of design certification. Remove insulating compound and underseal from vehicle (if present) in the area of the matting surfaces of the towing hitch. The vehicle manufacturer's specifications regarding trailer mass and max. vertical cup mass are decisive for driving whereat values for the towing hitch cannot be exceeded.

*D-value formula:*

$$\frac{\text{Max trailer weight [kg]} \times \text{Max vehicle weight [kg]}}{\text{Max trailer weight [kg]} + \text{Max vehicle weight [kg]}} \times \frac{9,81}{1000} = D \text{ [kN]}$$