

FITTING INSTRUCTION

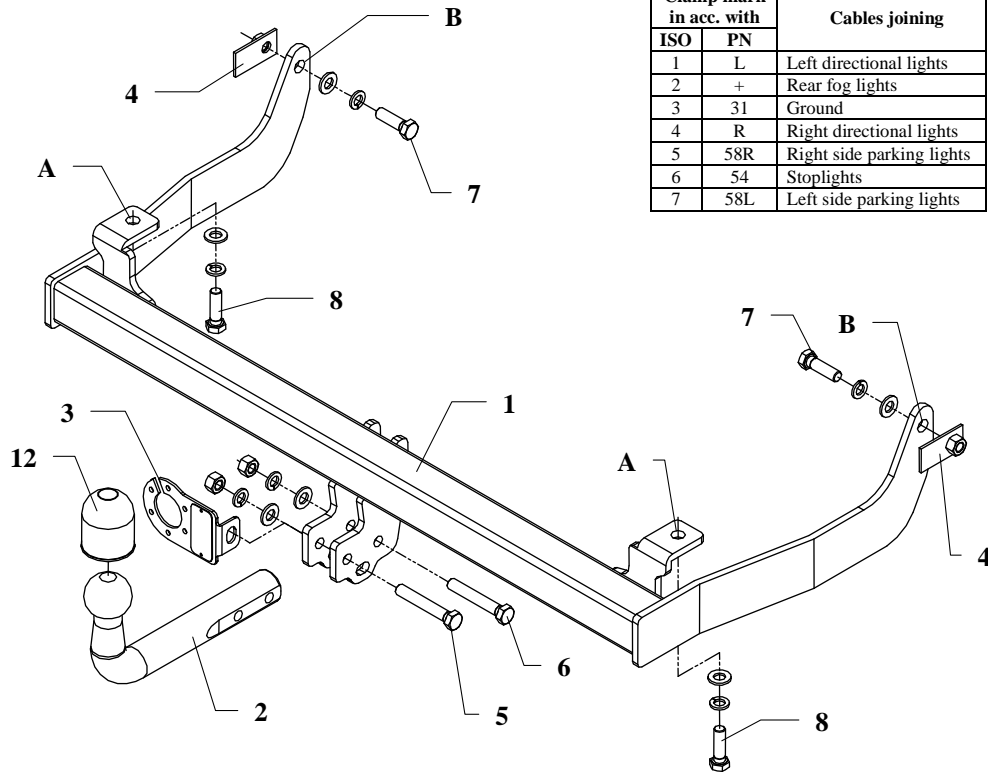

Clamp mark in acc. with		Cables joining
ISO	PN	
1	L	Left directional lights
2	+	Rear fog lights
3	31	Ground
4	R	Right directional lights
5	58R	Right side parking lights
6	54	Stoplights
7	58L	Left side parking lights

This towing hitch is designed to assembly in following cars:
VOLKSWAGEN CADDY passenger car/delivery van, produced since 11.1995 till 01.2004
SEAT INCA passenger car/delivery van produced since 11.1995 till 06.2003, catalogue no. **K31** and is prepared to tow trailers max total weight **1100kg** and max vertical load **50 kg**.

From manufacturer

Thank you for buying our product. Their reliability has been confirmed in many tests. Reliability of towing hitches depends also on correct assembly and right operation. For this reasons we kindly ask to read carefully this instruction and apply to hints.

The towing hitch should be install in points described by a car producer.

The instruction of the assembly

1. Take out a spare wheel.
2. Twist off bolts fastening bumper brackets.
3. Remove elongated, rubber plugs from left and right chassis members. To raised holes put plates with nuts (pos. 4).
4. Put to chassis main bar of towbar (pos. 1) and fix through holes pos. A using bolts M12x1,5x40mm (pos. 8) from equipment.
5. Through holes (pos. B) and original holes fix using bolts M12x40mm pos. 7 from equipment. Use plates with nuts pos. 4.
6. Fix tow-ball (pos. 2) and socket plate (pos. 3) using bolts M12x75mm (pos. 5) and M12x70mm (pos. 6).
7. Tighten all bolts according to the torque shown in the table.
8. Connect electric wires of 7-poles socket according to the instruction of the car. (Recommend to make at authorized service station)
9. Complete paint layer damaged during installation.

Torque settings for nuts and bolts (8,8):

M8	25 Nm	M10	55 Nm
M12	85 Nm	M14	135 Nm







NOTE

After install the towing hitch you should get adequate note in registration book (at authorised service station).The car should be equipped with:

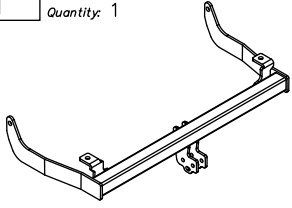
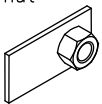
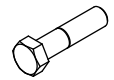
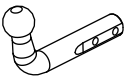
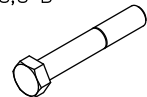
- Indicators
- Tow mirrors

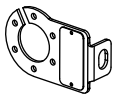
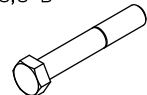
After 1000km check all bolts and nuts. The ball of towing hitch must be always kept clear and conserve with a grease.

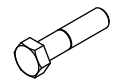
Part list:

Pos. 1	Name: Main bar Quantity: 1	Pos. 4	Name: Plate with nut Quantity: 2	Pos. 8	Name: Bolt 8,8 B Quantity: 2 Dim. : M12x1,5x40mm
					
Pos. 2	Name: Tow ball Quantity: 1	Pos. 5	Name: Bolt 8,8 B Quantity: 1 Dim. : M12x75mm	Pos. 9	Name: Nut 8 B Quantity: 2 Dim. : M12
					
Pos. 3	Name: Socket plate Quantity: 1	Pos. 6	Name: Bolt 8,8 B Quantity: 1 Dim. : M12x70mm	Pos. 10	Name: Plain washer Quantity: 6 Dim. : Ø 13 mm
					
		Pos. 7	Name: Bolt 8,8 B Quantity: 2 Dim. : M12x40mm	Pos. 11	Name: Spring washer Quantity: 6 Dim. : Ø 12,2 mm
					
			Pos. 12	Name: Ball cover Quantity: 1	



PPUH AUTO-HAK S.J.

Produkcja Haków Holowniczych
Henryk & Zbigniew Nejman
76-200 SŁUPSK ul. Słoneczna 16K
tel/fax (059) 8-414-414; 8-414-413
e-mail: office@autohak.com.pl
www.autohak.com.pl

Towing hitch (without electrical set)

Class: **A50-X** Cat. no. **K 31**

Designed for:

VOLKSWAGEN CADDY

Type: **passenger car/delivery van**

produced since 11.1995 till 01.2004

SEAT INCA

Type: **passenger car/delivery van**

produced since 11.1995 till 06.2003

Technical data:

D-value: 6,7 kN

maximum trailer weight: **1100 kg**

maximum vertical cup load: **50 kg**

Approval number according to Directive 94/20/EC: **e20*94/20*0209*00**

Foreword

This towing hitch is design according to rules of safety traffic regulations. The towing hitch is a safety component and must be installed only by qualified personnel. Any alteration or conversion to the towinh hitch is prohibited and would lead to cancellation of design certification. Remove insulating compound and underseal from vehicle (if present) in the area of the matting surfaces of the towing hitch.

The vehicle manufacturer's specifications regarding trailer load and max. vertical cup load are decisive for driving, and values for the towing hitch must not be exceeded.

D-value formula:

$$\frac{\text{Max trailer weight [kg]} \times \text{Max vehicle weight [kg]}}{\text{Max trailer weight [kg]} + \text{Max vehicle weight [kg]}} \times \frac{9,81}{1000} = D \text{ [kN]}$$