

## FITTING INSTRUCTION

Clamp mark in acc. with		Cables joining
ISO	PN	
1	L	Left directional lights
2	+	Rear fog lights
3	31	Ground
4	R	Right directional lights
5	58R	Right side parking lights
6	54	Stoplights
7	58L	Left side parking lights

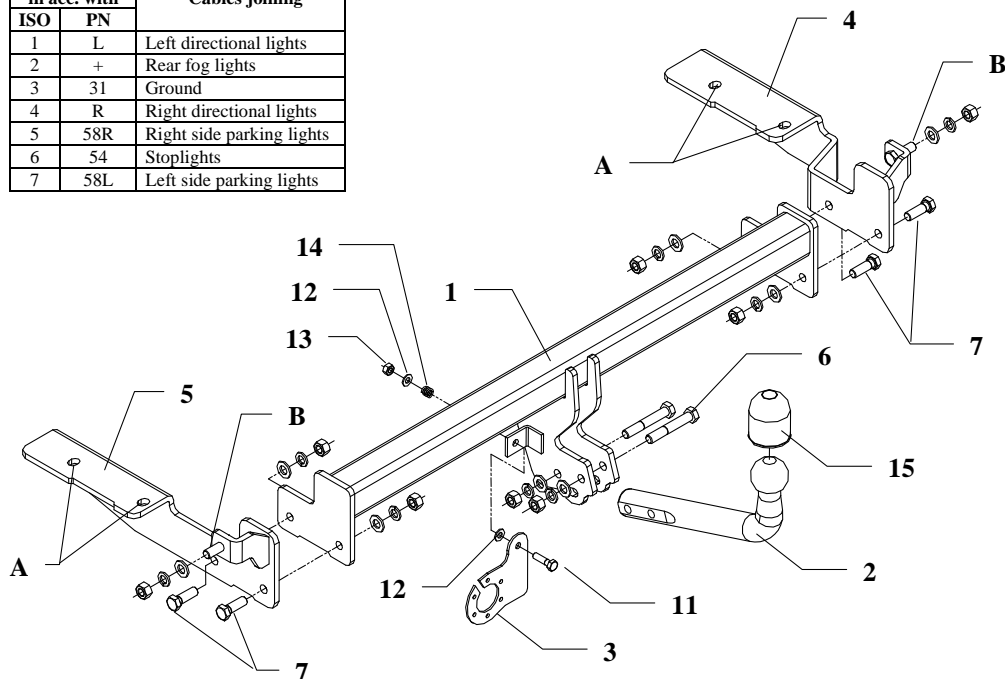

This towbar is designed to assembly in following cars:

**CHRYSLER GRAND VOYAGER, VOYAGER 2WD, VAN (GS)**, produced since 10.1995 till 03.2001, **DODGE CARAVAN, GRAND CARAVAN, 2 WD, VAN**, produced since 01.1995 till 03.2001, catalogue no. **CH30** and is prepared to tow trailers max total weight **1600 kg** and max vertical load **80 kg**.

### *From manufacturer*

Thank you for buying our product. Their reliability has been confirmed in many tests. Reliability of towbar depends also on correct assembly and right operation. For this reasons we kindly ask to read carefully this instruction and apply to hints.

*The towbar should be install in points described by a car producer.*

## The instruction of the assembly

1. From below the car untwist bolts fastening brackets of the bumper ( two per each side )  
- remove original tow eye ( not used any more).
2. In place of untwisted bolts put on the left side left bracket pos. 5 and on the right side put right bracket pos. 4. Fix it to the car by untwisted bolts (M12x1,25x40mm) through holes A and in points B twist nuts M12, loosely.
3. Between mounted brackets pos. 4 and 5 fix main bar of the towbar (pos. 1) using bolts M12x35mm (pos. 7).
4. Fix tow-ball (pos. 2) by bolts M12x75mm (pos. 6) from accessories.
5. Fix the socket plate (pos. 3) as shown on the drawing.
6. Tighten all bolts according to the torque shown in the table.
7. Connect electric wires of 7-pole socket according to the instruction of the car. (Recommend to make at authorized service station)
8. Complete paint layer damaged during installation.

Torque settings for nuts and bolts (8,8):

<b>M6</b> - 11 Nm	<b>M8</b> - 25 Nm	<b>M10</b> - 50 Nm
<b>M12</b> - 87 Nm	<b>M14</b> - 138 Nm	<b>M16</b> - 210 Nm

### NOTE

After install the towbar you should get adequate note in registration book (at authorised service station).The car should be equipped with:

- Indicators
- Tow mirrors

After 1000km of exploitation check all bolts and nuts. The ball of towbar must be always kept clear and conserve with a grease.

## Towbar accessories:

Pos. 1	Name: Main bar Quantity: 1	Pos. 5	Name: Left bracket Quantity: 1	Pos. 10	Name: Spring washer Quantity: 8 Dim.: $\varnothing$ 12,2 mm
Pos. 2	Name: Tow-ball Quantity: 1	Pos. 6	Name: Bolt 8,8 B Quantity: 2 Dim.: M12x75mm	Pos. 11	Name: Bolt 8,8 B Quantity: 1 Dim.: M8x30mm
		Pos. 7	Name: Bolt 8,8 B Quantity: 4 Dim.: M12x35mm	Pos. 12	Name: Plain washer Quantity: 2 Dim.: $\varnothing$ 8,5 mm
Pos. 3	Name: Socket plate Quantity: 1	Pos. 8	Name: Nut 8 B Quantity: 8 Dim.: M12	Pos. 13	Name: Nut 8 B Quantity: 1 Dim.: M8
Pos. 4	Name: Right bracket Quantity: 1	Pos. 9	Name: Plain washer Quantity: 8 Dim.: $\varnothing$ 13 mm	Pos. 14	Name: Spring Quantity: 1
		Pos. 15	Name: Ball cover Quantity: 1		



**PPUH AUTO-HAK Sp.J.**

Produkcja Zaczepów Kulowych  
Henryk & Zbigniew Nejman  
76-200 SŁUPSK ul. Słoneczna 16K  
tel/fax (059) 8-414-414; 8-414-413  
e-mail: [office@autohak.com.pl](mailto:office@autohak.com.pl)  
[www.autohak.com.pl](http://www.autohak.com.pl)

## Towing hitch (without electrical set)

Class: **A50-X** Cat. no. **CH30**

Designed for:

Manufacturer: **CHRYSLER**

Model: **VOYAGER, GRAND VOYAGER**

Type: **2WD, VAN (GS)**

produced since 10.1995 till 03.2001

Manufacturer: **DODGE**

Model: **CARAVAN, GRAND CARAVAN**

Type: **2WD, VAN**

produced since 01.1995 till 03.2001

Technical data:

**D-value: 9,72 kN**

maximum trailer weight: **1600 kg**

maximum vertical cup load: **80 kg**

Approval number according to Directive 94/20/EC: **e20\*94/20\*0220\*00**

## Foreword

This towbar is designed according to rules of safety traffic regulations. The towing hitch is a safety component and must be installed only by qualified personnel. Any alteration or conversion to the towing hitch is prohibited and would lead to cancellation of design certification. Remove insulating compound and underseal from vehicle (if present) in the area of the matting surfaces of the towing hitch.

The vehicle manufacturer's specifications regarding trailer load and max. vertical cup load are decisive for driving, and values for the towing hitch cannot be exceeded.

*D-value formula:*

$$\frac{\text{Max trailer weight [kg]} \times \text{Max vehicle weight [kg]}}{\text{Max trailer weight [kg]} + \text{Max vehicle weight [kg]}} \times \frac{9,81}{1000} = D \text{ [kN]}$$