



AUDI A6 AVANT  
AUDI A6 SEDAN

2005-  
2004 -

Cat. No. A/012

e20

e20\*94/20\*0721\*00

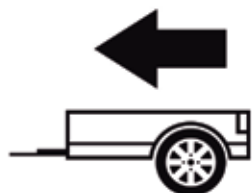



2100Kg



85Kg

**D** = 10,90kN

$$D \text{ (kN)} = \frac{\text{MAX kg} \times \text{MAX kg}}{\text{MAX kg} + \text{MAX kg}} \times 0,00981$$





**IMIOLA HAK-POL**

96-111 KOWIESY, CHOJNATA 23 A, POLAND

tel. +48 46 831 73 31, fax +48 831 74 29

e-mail: office@imiola.pl, www.imiola.pl

## PRZEKRÓJ A-A

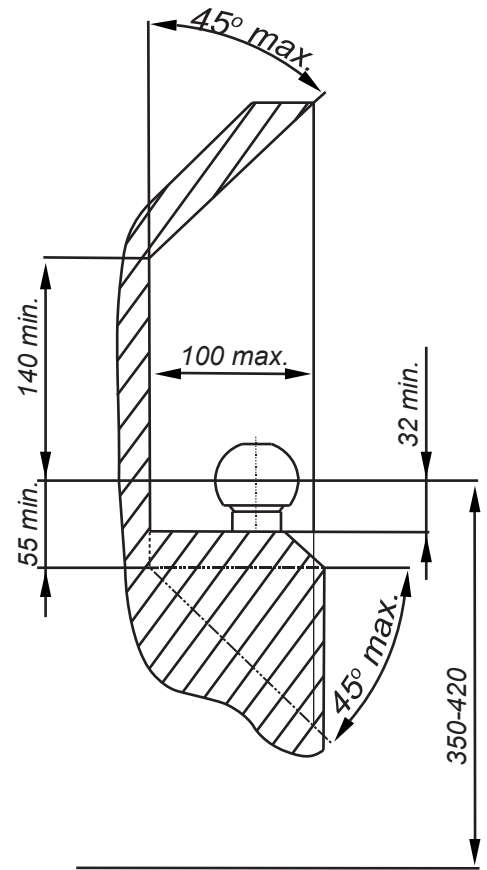
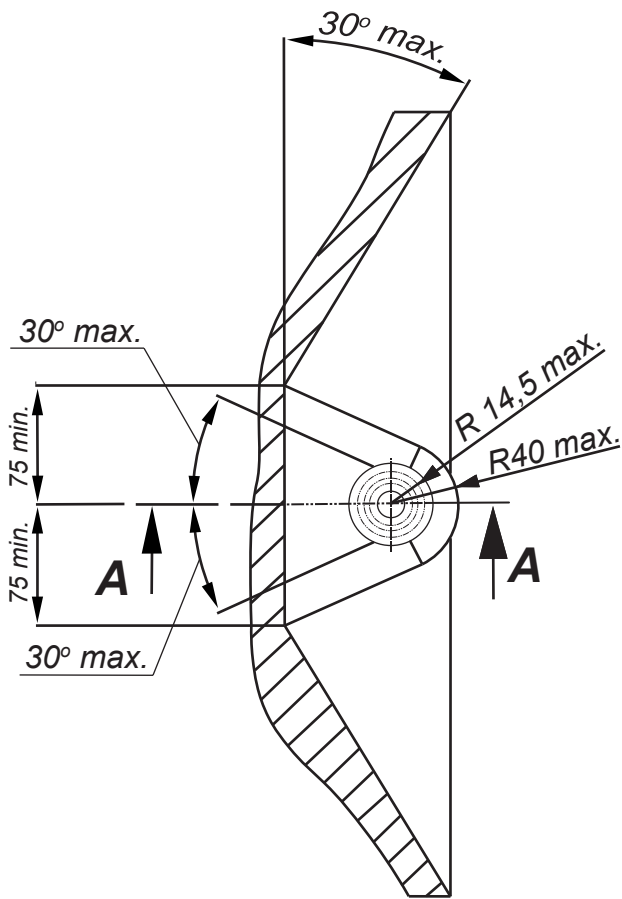

**PL** Należy zagwarantować przestrzeń swobodną według załącznika VII, rysunek 25a/b Regulaminu EKG ONZ 55.01 przy dopuszczalnym ciężarze całkowitym pojazdu.

**F** L'espace libre doit être garanti conformément à l'annexe VII, illustration de la réglementation 55.01 CE pour un poids total en charge autorisé du véhicule.

**GB** The clearance specified in appendix VII, diagram 25a/b of Regulation No. 55.01 UN EU must be guaranteed at laden weight of the vehicle.



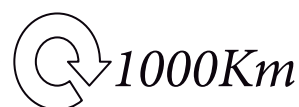

**D** Der Freiraum nach Anhang VII, Abbildung 25a/b der Vorschriften 55.01 EG ist zu gew 25a/bahrleisten bei zulässigem Gesamtgewicht des Fahrzeuges.

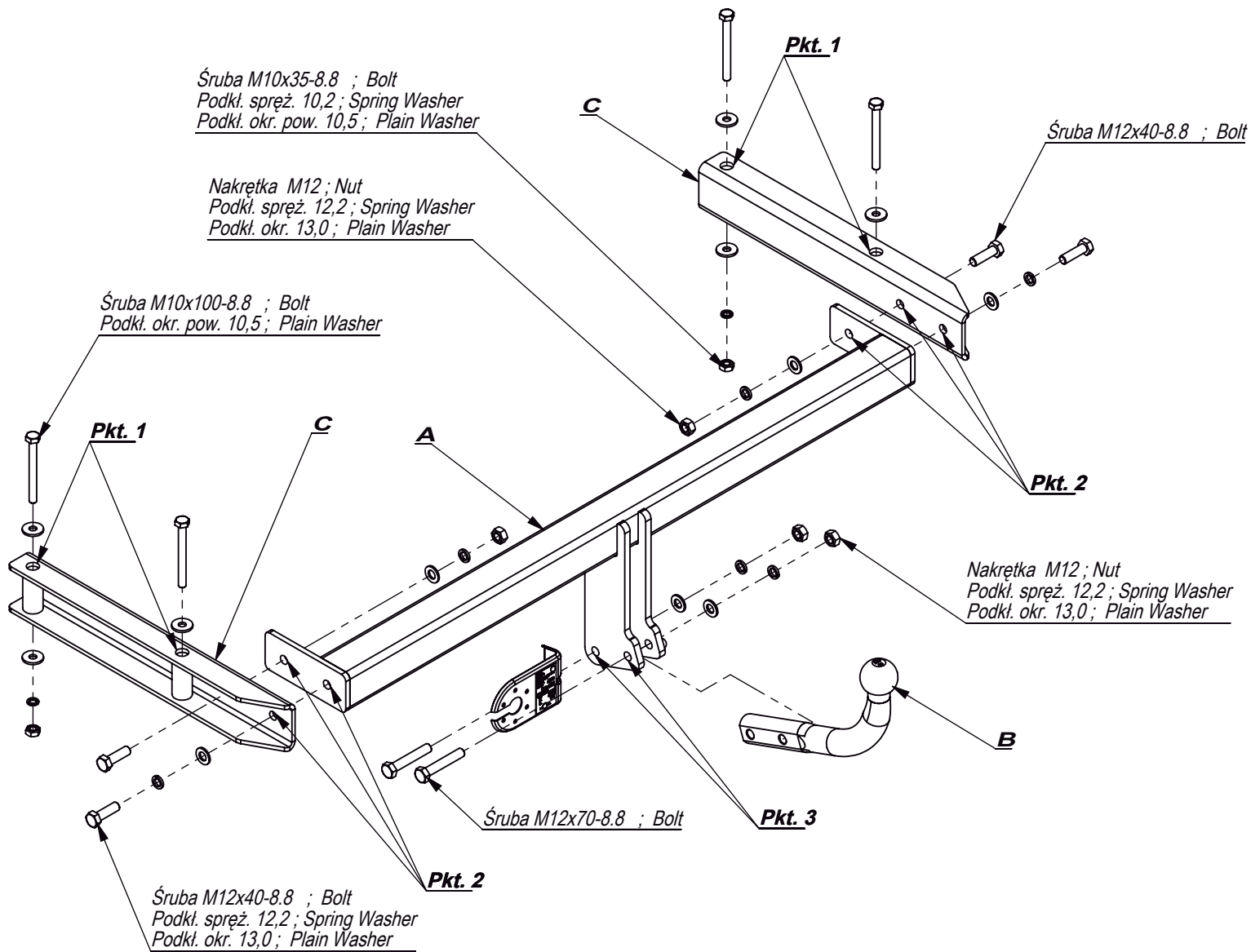
Moment skręcający dla śrub i nakrętek (8.8) Torque settings for nuts and bolts (8.8)	
M8	25Nm
M10	55Nm
M12	85Nm
M14	135Nm
M16	195Nm

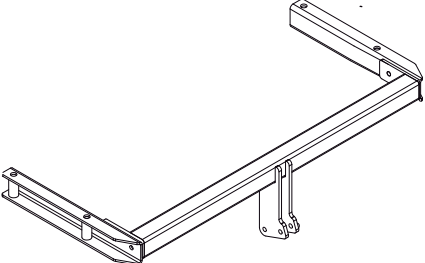
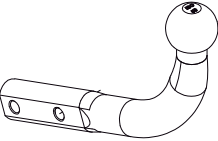
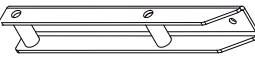
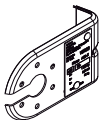
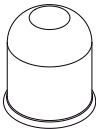



	A
	x1
	B
	x1
	C
	x2
	D
	x1
	E
	x1

	<b>M12x70 8.8</b>	2
	<b>M12x40 8.8</b>	4
	<b>M10x100 8.8</b>	4
	<b>M12</b>	6
	<b>M10</b>	2
	<b>Øx30</b>	6
	<b>M12</b>	6
	<b>M10</b>	4
	<b>M12</b>	6

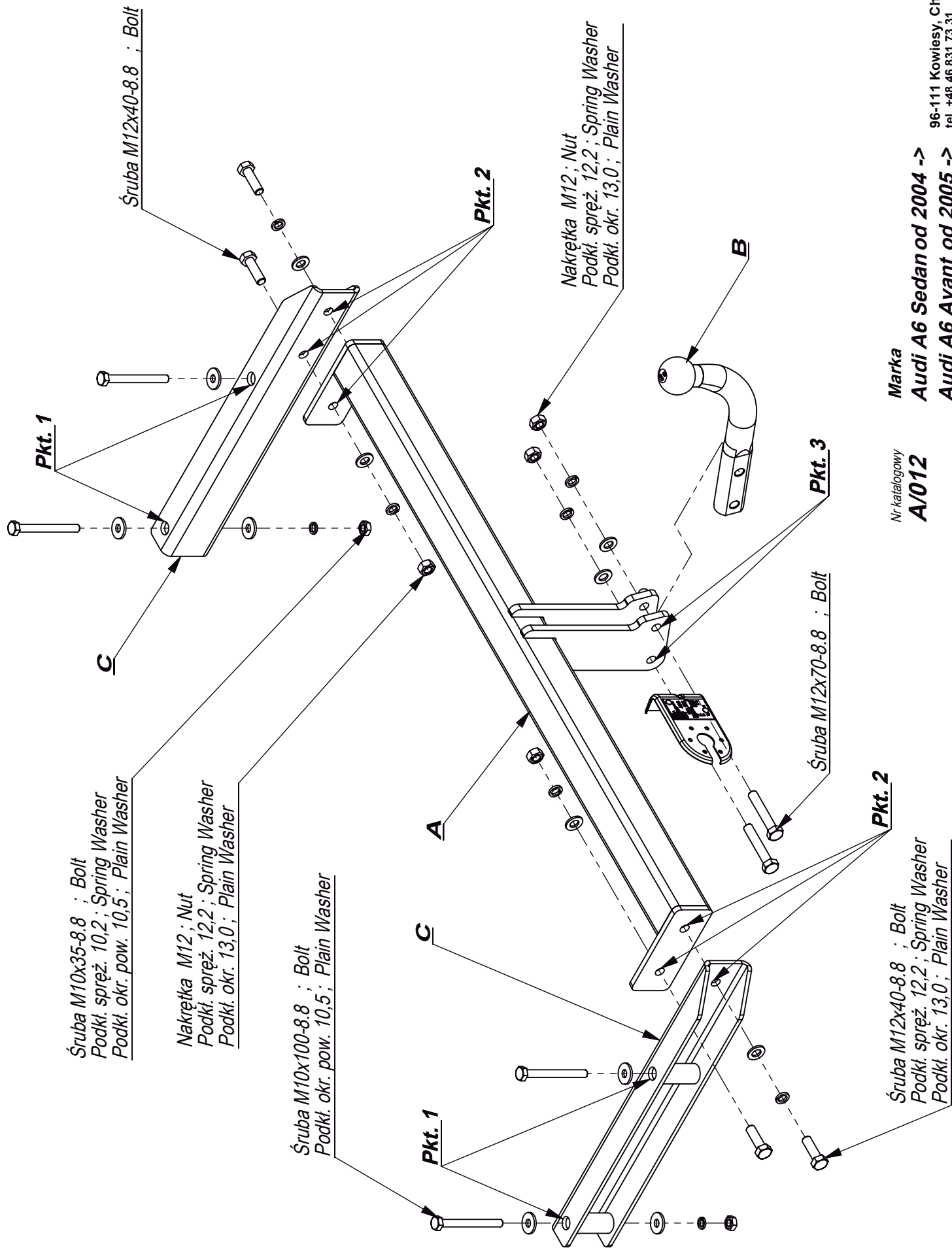

Nr katalogowy

**A/012**

Marka

**Audi A6 Sedan od 2004 ->**

**Audi A6 Avant od 2005 ->**

- Odkręcić zderzak.
- Odkręcić plastikowe elementy w bagażniku.
- Odkręcić belkę zderzeniową (nie będzie już wykorzystana).
- Do podłużnic wsunąć elementy haka C i poprzez technologiczne otwory w podłużnicach przykręcić lekko element C śrubami M10x100 8.8 (pkt 1).
- Do elementów C przykręcić belkę haka A śrubami M12x40 8.8 (pkt 2).
- Wszystkie śruby dokręcić z momentem wg tabeli.
- Wykonać wycięcie w dolnej części zderzaka 50x70.
- Przykręcić zderzak.
- Przykręcić kulę i blachę gniazda elektrycznego.
- Podłączyć instalację elektryczną.
- Przykręcić plastikowe elementy w bagażniku.

- Unscrew the bumper.
- Unscrew the plastic elements in the boot.
- Unscrew the bumper bar (it will not be used any more).
- Insert elements C in the metal clamps and screw slightly, through the technological holes in the metal clamps, with bolts M10x100 8.8 (point 1).
- Screw the main bar A to the elements C with bolts M12x40 8.8 (point 2).
- Tighten all the bolts according to the torque setting- see the table.
- Cut out the fragment measuring 50x70 in the lower part of the bumper.
- Screw the bumper.
- Fix the ball and electric plate.
- Connect the electric wires.
- Screw the plastic elements in the boot.

- Serrer le pare-chocs,
- Dévisser du longerons les fixations de pare-chocs (elles ne seront plus utilisées).
- Insérer les bords de crochet D aux longerons, Visser le crochet par les boulons M10x100 8.8 à travers les ouvertures de longerons en utilisant les couvre-joints C
- Visser le crochet d'attelage et socle de prise électrique,
- Raccorder le circuit électrique.
- Serrer tous les boulons avec un couple de serrage selon tableau,

